

# RELIABLE PERFORMANCE STARTS HERE

Engineered for dependability and efficiency, Overly Hautz motor mounts deliver consistent belt tension, easier maintenance, and longer equipment life.

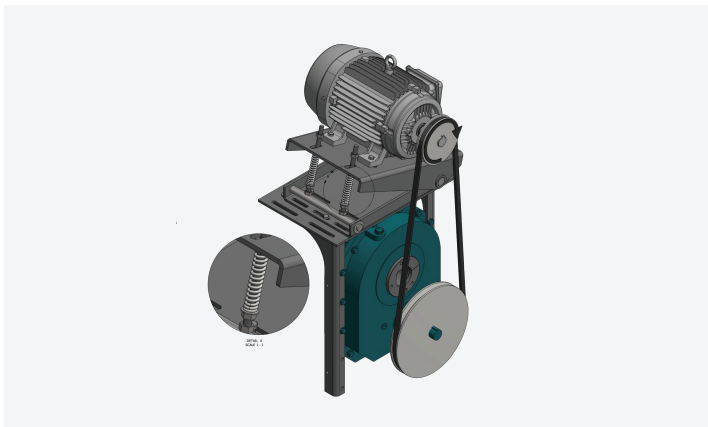

**OVERLY HAUTZ  
COMPANY**



## Automatic® Reducer Motor Mount (ARMM)

Delivers both mechanical and energy-saving advantages for equipment using gear drives or speed reducers. New patent pending design.

- Extends belt and bearing life
- Eliminates need for manual re-tensioning
- Quick belt changes without misalignment
- Reduces energy consumption
- Adapts to changing loads for peak efficiency
- Minimizes belt slippage and energy loss
- Cuts maintenance downtime and costs
- Supports sustainability initiatives

*Automatic® Reducer Motor Mount: A compact clamshell pivot with compressed springs automatically maintains proper belt tension, boosting performance and energy efficiency.*



## Belt Guard

The Overly Hautz Belt Guard is Dodge® Torque-Arm® compatible and provides a safe, lightweight, and easy-to-install protection solution for belt-driven systems using gear drives or gear reducers.

- Slotted metal panel design for ventilation and reduced weight
- Mounting hardware included for flexible installation
- Hinged and lift-off cover for easy maintenance access
- Accommodates most common sheave diameters
- Seamless integration with reducer and motor mount holes
- Meets industry safety requirements

*Belt Guard: Dodge® Torque-Arm® Compatible, For Use With Gear Drives, Gear Reducers, and Speed Reducers, Steel Construction*

## FIND THE RIGHT SOLUTION

Our team can help you select the best Overly Hautz mount for your application.

Phone: (513) 932-0025  
Fax: (513) 932-1688  
Email: [motorbases@overlyhautz.com](mailto:motorbases@overlyhautz.com)



# RELIABLE PERFORMANCE STARTS HERE

The reducer motor mount ensures stable performance, simple installation and adaptability for diverse applications.



**OVERLY HAUTZ  
COMPANY**

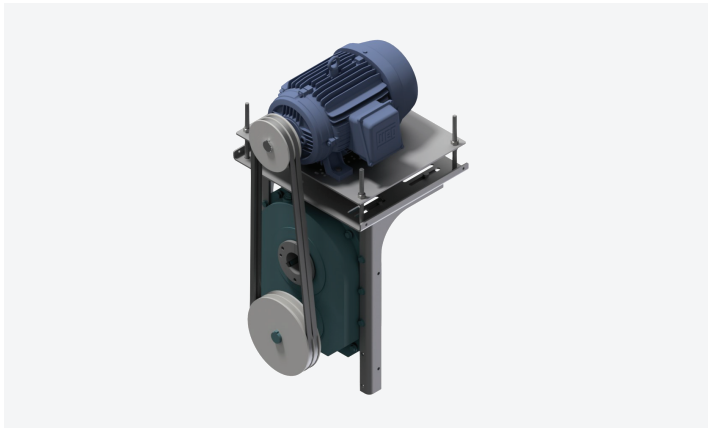

## Reducer Motor Mount

Fully compatible with Dodge® Torque-Arm® Motor Mounts. It secures motors and TA® reducers for a wide range of industrial applications.

- Provides secure motor fastening and consistent belt tension
- Angle iron brackets ensure singular stability in tough applications
- Precision alignment simplifies installation and ensures proper fit
- Flexible adjustability accommodates multiple motor configurations
- Compatible with both NEMA and IEC frame motors
- Available in sizes 0-12 to fit a wide range of applications
- Supports side mounting, ideal for screw conveyor drives
- Reduces downtime with standardized hardware and quick setup

*Reducer Motor Mount, For Use With: Dodge® Torque-Arm® Speed Reducers, Sizes 0-12, Compatible with NEMA and IEC Motors*



## Belt Guard

The Overly Hautz Belt Guard is Dodge® Torque-Arm® compatible and provides a safe, lightweight, and easy-to-install protection solution for belt-driven systems using gear drives or gear reducers.

- Slotted metal panel design for ventilation and reduced weight
- Mounting hardware included for flexible installation
- Hinged and lift-off cover for easy maintenance access
- Accommodates most common sheave diameters
- Seamless integration with reducer and motor mount holes
- Meets industry safety requirements

*Belt Guard: Dodge® Torque-Arm® Compatible, For Use With Gear Drives, Gear Reducers, and Speed Reducers, Steel Construction*

## FIND THE RIGHT SOLUTION

Our team can help you select the best Overly Hautz mount for your application.

Phone: (513) 932-0025  
Fax: (513) 932-1688  
Email: [motorbases@overlyhautz.com](mailto:motorbases@overlyhautz.com)

